

Performance

Lifting height — on tyres	6973.0 mm
Rated capacity	3500 kg
Capacity (at max. height on tyres)	3500 kg
Capacity (at max. reach on tyres)	1500 kg
Max. reach on tyres	4002.0 mm

Weights

Weight (unladen)	7470 kg
------------------	---------

Traction

Standard tyres	MICHELIN 460/70R24 159A8/159B IND TL XMCL
1st gear / low range	6.0 km/h
1st gear / high range	18.0 km/h
2nd gear / low range	12.0 km/h
2nd gear / high range	40.0 km/h

Drive System

Transmission	Hydrostatic with electronic regulation
Main drive	Hydrostatic motor + 2 speed gearbox

Engine

Make / Model	Bobcat D34
Fuel	Diesel
Cooling	Coolant
Rated power (ISO 14396:2002) at 2400 RPM	100.0 HP
Rated power (ISO 14396:2002) at 2400 RPM	74.5 kW
Maximum torque at 1400 RPM	430.0 Nm
Number of cylinders	4
Displacement	3.40 L

Hydraulic System

Pump type	Gear pump with LS valve
Pump capacity	100.00 L/min
Relief valve pressure setting	250.00 bar

Cycle Times

Lift time - no load	8.0 s
Lower time - no load	6.0 s
Telescope in time at max. reach - no load	6.5 s
Telescope in time at max. height - no load	6.5 s
Telescope out time at max. reach - no load	7.1 s
Telescope out time at max. height - no load	7.1 s

Brakes

Engine braking	Hydrostatic
Parking and emergency brake	Passive brake

Fluid Capacities

Fuel tank	138.00 L
Hydraulic reservoir	59.00 L

Environmental

Operator noise level (LpA) (EN 12053)	74 dB(A)
Level of acoustic power (LWA)	106 dB(A)
Whole body vibration (EN 13059)	1.20 ms ⁻²

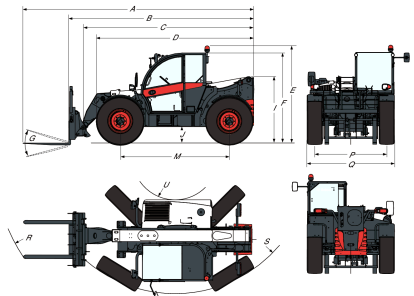
Dimensions

(-) 900.0 mm	(L) 1356.0 mm
(A) 6074.0 mm	(M) 2870.0 mm
(B) 4869.0 mm	(N) 643.0 mm
(C) 4763.0 mm	(O) 1013.0 mm
(D) 4145.0 mm	(P) 1895.0 mm
(E) 2561.0 mm	(Q) 2300.0 mm
(F) 2374.0 mm	(R) 4925.0 mm
(G) 135.0°	(R) 5015.0 mm
(I) 1752.0 mm	(S) 3714.0 mm
(J) 430.0 mm	(U) 1092.0 mm

Load Charts

With forks on 24 inch tyres

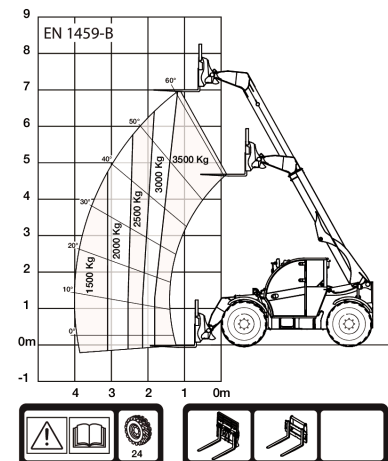
TL35.70

99207 G7

7296047

Options

Air conditioning	Manitou carriage with manual attachment lock
Boom stop	Blue lights for henhouses
Custom colour	Boom suspension
Fire extinguisher	Forward/Reverse control on joystick and steering wheel
Forward/Reverse control on Steering Wheel Lever (no longer on joystick)	Rear auxiliary line
Protective grill for windshield (front and roof)	Rotating tow hitch with height adjustment (auto-lock/German style)
Wheel wedge	(including rear electric socket)
Keyless ignition (start/stop with keypad)	Rotating tow hitch with height adjustment (manual locking) (including rear electric socket)
Quicktach carriage with hydraulic attachment lock (boom wiring harness mandatory)	Tool box
Standard engine ignition (with key) with additional keypad security	Hydraulic pick-up tow hitch (including rear electric socket) (rear flat mirror mandatory)
Manitou carriage with hydraulic attachment lock (boom wiring harness mandatory)	Michelin tyres - set of 4 x 500/70R24" XMCL (AGRICULTURAL) (Except

overseas countries -
Container shipping)