

# TL25-60 75 V R-Series Telescopic Handler

## Telescopic Specifications

### Performance

Rated capacity	2500 kg
Capacity (at max. height on tyres)	1800 kg
Capacity at max. reach (16.5" tyres)	800 kg
Lifting height on tyres with BT carrier	5900.0 mm
Lifting height on tyres with QT carrier	5800.0 mm
Tilt Breakout force - ISO8313	3300 daN
Drawbar pull (16.5" tyres)	3350 daN
Drawbar pull (20" tyres)	2900 daN
Max. gradeability (16.5" tyres)	33.0°
Max. reach (16.5" tyres QT)	3400.0 mm
Max. reach (16.5" tyres BT)	3300.0 mm
Reach at max height on tyres (16.5" tyres QT)	616.0 mm
Reach at max height on tyres (16.5" tyres BT)	539.0 mm

### Cycle times

Boom raising	5.6 s
Boom lowering	4.0 s
Boom extension	5.4 s
Boom retraction	3.4 s
Crowding	2.9 s
Dumping	2.7 s

### Weights

Unladen weight (16.5" tyres)	4308 kg
Unladen weight (20" tyres)	4413 kg

### Engine

Make / Model	Bobcat DM02
Fuel	DIESEL
Rated power @ 2400rpm (ISO 14396)	55.0 kW
Rated speed	2400.0 RPM
Maximum torque @ 1600 rpm	280.0 Nm
Number of cylinders	4.0
Displacement	2.39 L

### Hydraulic system

Pump type	Gear pump
Pump capacity	80.00 L/min
Relief valve pressure setting	250.00 bar
Control valve type	"Flow sharing valve Electro proportional control"

### Drive system

Transmission	Hydrostatic with electronic regulation
Main Drive	Hydrostatic motor

### Traction

Standard Tyres	CAMSO 12-16,5 SKS 532 12PR (R1 category)
Max speed - turtle mode (16.5"/20")	6,9 / 7,5 km/h
Max speed - rabbit mode (16.5"/20")	27,3 / 29,6 km/h

### Brakes

Engine Braking	Hydrostatic
Parking and Emergency brake	Passive brake
Service Brake	Oil immersed discs

### Steering

Steering Mode	2 wheel steering / 4 wheel steering / Crab-steering
---------------	---

### Fluid Capacities

Fuel tank	65.00 L
Hydraulic tank	42.00 L
Hydraulic system	70.00 L

### Environmental

Operator noise level (LpA) (EN 12053)	75 dB(A)
Level of acoustic power (LwA)	104 dB(A)
Whole body vibration (EN 13059)	1.20 ms <sup>-2</sup>

### Dimensions

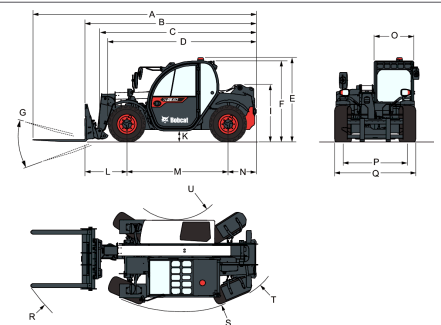

BT Values marked with \* - 20" wheels

(A)	5208.0 mm	(K*)	289.0 mm
(B)	3989.0 mm	(L)	1044.0 mm
(C)	3647.0 mm	(M)	2360.0 mm
(D)	3442.0 mm	(N)	662.0 mm
(D*)	3488.0 mm	(O)	930.0 mm
(E)	2085.0 mm	(P)	1500.0 mm
(E*)	2124.0 mm	(Q)	1832.0 mm
(F)	1930.0 mm	(R)	4271.0 mm
(F*)	1969.0 mm	(R*)	4593.0 mm
(G)	134.0°	(S)	3235.0 mm
(I)	1340.0 mm	(S*)	3729.0 mm
(I*)	1379.0 mm	(U)	1165.0 mm
(K)	250.0 mm	(U*)	1676.0 mm

### Load Charts

#### Load Charts

