

FARMLIFT

MAXIMUM REACH 6.1 - 9.1 m
633 / 636 / 737 / 742 / 935





FARMLIFT. A MODEL TO LIFT EVERY LOAD.

Take your business to new heights.

Case IH continues its tradition of meeting the diverse needs of farms with the new generation of Farmlift telescopic loaders. These machines, ranging from 3,300 to 4,200 kg lift capacities and reaching up to 9.1 m, embody the ruggedness, reliability, and comfort synonymous with Case IH.

With enhanced styling, including new exterior design elements, and a complete new cab interior, they offer a fresh and modern look. Featuring a new 7 inch display and ergonomic controls on the armrest, they provide improved functionality. Equipped with smart hydraulics and a 160 l/min CCLS pump, they deliver optimal performance.



COMFORT

The new Farmlift gives you a seamless operation experience with a better overview, its user-friendly joystick, innovative 7 inch display, and redesigned controls.



EFFICIENCY

Take efficiency to new heights : Engine hood perfectly protected within the wheelbase, coupled with an innovative load monitor indicator featuring LED lights to ensure adherence to load limits.



PRODUCTIVITY

Boost your material handling rates with efficient 160 l/min CCLS pump, advanced electro-hydraulic self-leveling of tool carrier for precise control, and superior boom suspension for comfortable transport applications.

THE NEW FARMLIFT	2 - 3
RANGE	4 - 5
INTRO	6 - 7
CAB	8 - 9
ENGINE & TRANSMISSION	10 - 11
BOOM & HYDRAULICS	12 - 13
SERVICE SOLUTIONS & SPECS	14 - 15



THE RIGHT FARMLIFT FOR EVERY JOB

Elevated Performance

From the 633 with 6.1 m reach, to the work-hungry 4,200 kg max capacity of the 742 and the enormous 9.1 m reach of the 935, and plenty of models in between, there's a machine to meet every need in the Farmlift range. We designed and built the range to meet the varied needs of today's agriculture – from small farms to the largest operations. Whatever model you choose, you know you can count on superior operating comfort, short loading times and quick vehicle response.

CONFIGURE
YOUR FARMLIFT
HERE:



SCAN ME

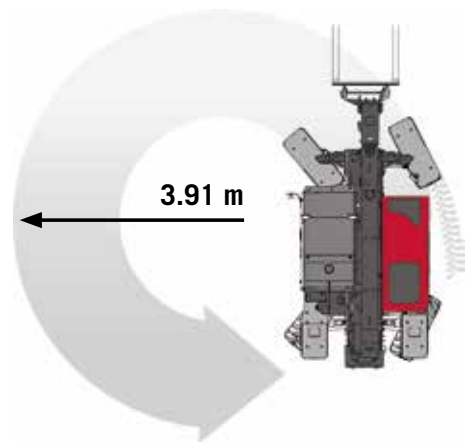

FARMLIFT 633 / 636

Perfect for businesses with light to medium material handling volumes and diverse applications.

- FPT Stage 5 | 4 cylinders 4,500 cm³
- 6x3 fullpowershift transmission
- 4WD with Limited-Slip-Differential
- Standard for front axle / optional for rear axle
- 460/70R24 or 500/70R24
- HIGH CAPACITY BOOM**
6.1 m lift height capacity with 3.3 / 3.6 t lift capacity
- ALL-ROUND VISIBILITY**
9 % better visibility

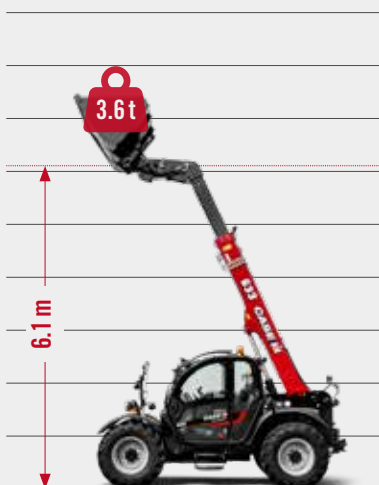

FARMLIFT 737 / 742

Suited for businesses with extensive material handling volumes and strict requirements concerning efficiency, dependability, and convenience.

- FPT Stage 5 | 4 cylinders 4,500 cm³
- 6x3 fullpowershift transmission
- 4WD with Limited-Slip-Differential
- Standard for front axle / optional for rear axle
- 460/70R24 or 500/70R24
- HIGH CAPACITY BOOM**
7 m lift height capacity with 3.7 / 4.2 t lift capacity
- ALL-ROUND VISIBILITY**
9 % better visibility

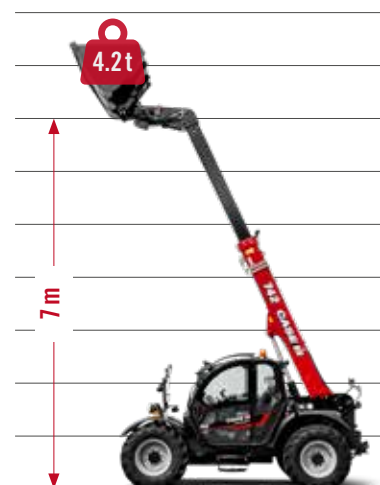

FARMLIFT 935

The Farmlift 935 is the perfect choice for those seeking high lift heights.

- FPT Stage 5 | 4 cylinders 4,500 cm³
- 6x3 fullpowershift transmission
- 4WD with Limited-Slip-Differential
- Standard for front axle / optional for rear axle
- 460/70R24 or 500/70R24
- HIGH CAPACITY BOOM**
9.2 m lift height capacity with 3.5 t lift capacity
- ALL-ROUND VISIBILITY**
9 % better visibility



DESIGNED FOR HANDLING EFFICIENCY

The all new Farmlift

160 l/min
piston pump

360°
all-round visibility



The Farmlift's transformation isn't merely an upgrade; it's a game-changing breakthrough. This remarkable evolution embodies power, all while setting new standards in efficiency and productivity. With improved ergonomics, unparalleled comfort, enhanced visibility, and accelerated cycle times, the Farmlift promises an intuitive, high-tech experience that elevates farming operations to new heights.

NEW STYLING AND VISIBILITY

- New bonnet design
- 9 % better visibility to the right-hand side
- Excellent 360° visibility all-round
- High visibility roof ensures a perfect view of the loader

ELECTRO-HYDRAULIC SELF-LEVELLING OF TOOL CARRIER

- Perfect accuracy in self levelling
- Less maintenance cost and time

AFS CONNECT TELEMATICS

- Manage your machine data and fleet
- Proactive business decisions thanks to real time notifications
- 1, 3 or 5 years available

MAXIMUM STABILITY

- Low centre of gravity
- Rear mounted boom acts as a counter balance
- Longer wheelbase of 3 m

146 hp
max power

EASY MAINTENANCE

- Extended engine service interval (1000 hours)
- Unique compact HI-eSCR2 exhaust gas aftertreatment system "for life" with no maintenance needed
- One piece bonnet and side panels allow easy access to the entire engine bay
- Fold-out radiators for easy cleaning

Models	Lift capacity	Max. reach	Engine rated / Max. power	Transmission	Load sensing hydraulic system
Farmlift 935	3,5 to	9.1 m	121 hp / 133 hp	6x3 Autoshift	Variable Piston Pump 140 l
Farmlift 742	4.2 to	7.0 m	129 hp / 146 hp	6x3 Autoshift	Variable Piston Pump 140 l / optional 160 l
Farmlift 737	3.7 to	7.0 m	121 hp / 133 hp	6x3 Autoshift	Variable Piston Pump 140 l
Farmlift 636	3.6 to	6.1 m	129 hp / 146 hp	6x3 Autoshift	Variable Piston Pump 140 l / optional 160 l
Farmlift 633	3.3 to	6.1m	121hp / 133 hp	6x3 Autoshift	Variable Piston Pump 140 l



A CAB THAT PUTS YOU FIRST

Take command in comfort

Upon entering the expansive and updated cab of our latest range, you'll instantly appreciate the enhanced right-side visibility, courtesy of a streamlined bonnet design, and a quieter environment. This comprehensive revamp offers unobstructed operator visibility and pairs it with our newly designed ergonomic controls and instruments for intuitive operation.

BEST-IN-CLASS VISIBILITY

Enhanced Visibility: The new full-length design of the Case IH Telehandler incorporates a new bonnet design that increases right-hand visibility by 9 %. It also features a high-visibility roof, providing an optimal upward view when working at height and a clear forward view over the dashboard for convenient attachment changes.

INSTRUMENTATION WITH STYLE

The advanced 7 inch display offers an at-a-glance view of all machine parameters, simplifying the setup of all machine functions. Additionally, the display incorporates the feed from a reverse camera, enhancing safety and maneuverability.

DESIGNED FOR COMFORT AND SAFETY

A wide door, accompanying steps, and rails ensure effortless entry into the climate-controlled cab. Emphasizing comfort, an air-suspended seat is provided, while an adjustable steering column simplifies accessibility. A rear-view camera is optional.

FINGERTIP CONTROL AND ERGONOMICS

The advanced joystick, mounted on the seat, offers adjustable sensitivity for precision in controlling boom movements, managing both transmission and hydraulics. Positioned conveniently on the armrest, the new keypad puts critical functions within easy reach, ensuring clear visibility and accessibility from the operator's seat.

NEW LOAD MOMENT INDICATOR (LMI)

The LED lights clearly indicate the machine's current load level to the operator.





ENGINE/
TRANSMISSION

THE POWER YOU NEED

For any application

Engineered for exceptional fuel efficiency and high-level performance, Case IH Farmlifts incorporate trusted components for reliable operation. These are your dependable worktools, ready to tackle critical and demanding tasks.

POWER AND TORQUE

All Farmlift models boast a 4.5 L NEF engine with HI-eSCR2 for Stage V compliance. Farmlift 636 and 742 deliver 146 hp at impressive fuel efficient 1,800 rpm. Maximum torque levels of up to 591 Nm at 1,500rpm keep the machine pushing in the most arduous of conditions. The 133hp maximum power engine in the 633, 737 and 935 models ensure there is always sufficient power to delivering fast cycle times and full job versatility.

TIME-EFFICIENT. COST-EFFICIENT

Daily maintenance is easily managed thanks to the wide opening one piece bonnet and side panels. And with 1000-hour service intervals, Farmlift telehandlers require the minimum of regular scheduled care.

SMART DESIGN

Courtesy of a compact design of the engine, the bonnet has become a fresh styling that significantly improves right hand visibility for the operator. It also facilitates daily checks as oil level dipstick and radiators that can be easily accessed and thoroughly cleaned.

AFTERTREATMENT SYSTEM "FOR LIFE"

The compact HI-eSCR2 system adopts an aftertreatment system "for life". In other words, no replacing components or mechanical cleaning during its whole lifecycle.

ADVANTAGES

- Powerful Stage V engines
- Hi-eSCR 2 after-treatment system
- Engine offer matches the requirements of each Farmlift
- Impressive torque even at lower engine speeds
- 1000-hour oil change intervals

WE SHIFTED UP A GEAR

For economic driving

Every Farmlift model comes standard with an electronically controlled 6x3 fullpowershift transmission, promising outstanding performance. Models equipped with a 145 hp engine feature a 40 kph transmission, providing best performance for road transport.

SHIFTING MODES

The standard 6x3 Autoshift is fully automatic through the forward speeds and can also be operated with the semi-automatic through forward gears 2-3-4. These models benefit from 40 kph top speed for faster travel between jobs, and a memory shuttle feature, where the power shuttle selects the last-used forward and reverse gear when changing direction.

SMOOTH OPERATION

Leveraging an innovative torque converter design, Farmlift delivers unparalleled response and immediate start-up. With wet multi-disc clutches, smooth gear transitions are ensured. A declutch button and an electronic modulation system further optimize operations, enhancing gear ratios for efficient loading applications.

STRONG AXLES FOR HIGH PAYLOAD

All Farmlifts are fitted with high dynamic load capability axles with limited slip differential (LSD) on the front axle, another can be specified for the rear axle. Inboard wet disc service brakes offer excellent stopping power whilst being well-protected and simple to service.

FOR SENSITIVE TASKS

Powershuttle commands are ergonomically positioned on the joystick, facilitating smooth directional shifts without letting go of the joystick. Moreover, advanced customization options are available, permitting the tailoring of Powershuttle's responsiveness to match personal preferences.



THE BEST BOOM IN THE BUSINESS

Boosted productivity at any height

Operators of Case IH Farmlift can trust in a sturdy telescopic boom that offers exceptional torsion resistance and payload capacity.

ELECTRO-HYDRAULIC SELF-LEVELLING

Using electronic sensors, this unique feature accomplishes automatic attachment levelling, bypassing the need for a telehandler's compensation cylinder. The benefits include full bucket capacity with no losses, great attachment levelling accuracy, less operator effort, and reduced maintenance time and cost.

SMOOTH RIDE CONTROL

Boom suspension enhances safety and comfort, delivering a smoother ride and improved stability.

STABILITY AND AGILITY

With a rear-mounted boom and a long wheelbase, it guarantees stability. Its under 4 m turning radius coupled with three steering modes ensures exceptional agility, even in tight spots. All these are made possible by a robust H-shaped ladder chassis, making it a specialist of handling high payloads.

TWO ANGLE SENSORS PROVIDE MORE PRECISE MOVEMENT AND LEVELING OF ATTACHMENTS



FULL HYDRAULIC POWER

YOUR BEST LIFTING ASSET

The Farmlift's hydraulic system offers electro-hydraulic, proportional functions through a CCLS load-sensing system, ensuring precise control and fast response. It also includes smart features such as bucket return, adjustable boom reactivity, and shaking function to boost productivity thanks to shorter cycle times.

SPEED UP YOUR LOADING CYCLES

Two Farmlift models can come with a new variable displacement piston pump that delivers 160 l/min of hydraulic power for improved hydraulic multi-functioning.

EXTRA COMFORTABLE

All hydraulic features are electro-proportionally controlled by the integrated multifunction electronic joystick, located on the end of the seat armrest, offering ergonomic excellence. Furthermore, the system supports the simultaneous use of three functions, boosting efficiency while reducing downtime.

SMART HYDRAULIC FEATURES

The SMART HYDRAULIC FEATURES package offers intelligent systems for enhanced operator comfort, convenience, and task efficiency. One notable feature is the bucket shaking function, which efficiently empties sticky materials and accurately portions straw or silage.

Additionally, the automatic 'return to position' feature allows for seamless movement of attachments to a pre-set target position from any initial situation.

- Adjustable boom responsiveness
- Adjustable continuous flow w/engine speed control
- Vertical lift

QUICK MOUNTING AND DISMOUNTING

The optional quick coupling/uncoupling system option available on all Farmlifts makes changing attachments as fast and safe as possible.

ADVANTAGES

- CCLS 160 l/min. pump for shorter cycle times
- Auxiliary pressure release (APR) switch simplifies connecting attachments





PARTS AND SERVICES

Solutions for your farming

Our professional dealer network backed up by local Case IH teams, industry-leading Case IH support tools, modern training methods, best-in-class replacement parts, support and logistics performance. All you need for an excellent all-encompassing after-sales service to keep you farming.

GENUINE PARTS THE IDEAL CHOICE

Our wide range of top quality genuine parts can help maintain the full potential of your machine, season after season, guaranteeing top performance, utmost productivity and high residual value.

REMAN PARTS REMANUFACTURED

Cutting-edge technology and strict quality testing enable us to rebuild essential machine components to new-part standards.

ACCESSORIES LINE BUSINESS SOLUTIONS

Our engineers also develop solutions to cover every one of your individual demands, packaged into kits and designed to help improve business efficiency. Your Case IH dealer offers a host of partner-branded tools, small parts and accessories provided by selected partner suppliers.

MAXSERVICE AROUND THE CLOCK. AROUND THE COUNTRY.

The Case IH support operates around the clock in high season, in close partnership with the dealer network, to minimise any downtime you might experience. Your dealer, together with Case IH Parts & Service team, has the main goal of getting you back to work as quickly as possible. Solutions may come through the priority shipment of needed parts (24/7), the support on field of Case IH technicians, courtesy units wherever applicable.

SAFEGUARD WARRANTY PROTECT YOUR INVESTMENT

The Case IH Extended Warranty program under the same condition as the first year. SAFEGUARD WARRANTY allows you to protect your investment from exposure to risk of unexpected repair cost, farm with peace of mind, keep operating costs under control and, at same time, increase machine resale value.

* ask your Dealer for the availability, terms and conditions of Safeguard Warranty for your new Case IH machine.



OPTIMAL FINANCING SOLUTION FOR EVERY INVESTMENT

CNH Industrial Capital is the financing company for Case IH. Our employees are financial experts and have many years of experience in agriculture. We not only know about Case IH products and the market – we also understand the individual requirements of your operations. Therefore we are always able to offer you a financial solution for your new investments that is tailored specifically to your operational requirements. Our most important goal is improving the profitability of your investments!

MODELS	FARMLIFT 633	FARMLIFT 935	FARMLIFT 636	FARMLIFT 737	FARMLIFT 742
Max. lift capacity (kg)	3,300	3,500	3,600	3,700	4,200
Max. lift height (m)	6.1	9.1	6.1	7	
HYDRAULICS					
Piston Pump (140 / 160) litres	● / -	● / -	○ / ●	● / -	○ / ●
Hydraulic Oil tank capacity (litres)			105		
CYCLING TIMES (SECONDS)					
Lift (140 L / 160 L piston pump)	6.7 / -	6.7 / -	6.7 / ?	6.7 / -	6.7 / ?
Lower (140 L / 160 L piston pump)	5.2 / -	5.2 / -	5.2 / ?	5.2 / -	
Extend (140 L / 160 L piston pump)	5.5 / -	7.9 / -	5.2 / ?	6.2 / -	
Retract (140 L / 160 L piston pump)	3.7 / -	6.3 / -	3.7 / ?	4.5 / -	
Dump (140 L / 160 L piston pump)	2.8 / -	2.8 / -	2.8 / ?	2.8 / -	
Rollback (140 L / 160 L piston pump)	2.8 / -	2.9 / -	2.8 / ?	2.9 / -	
Total Time (140 L / 160 L piston pump)	26.4 / -	31.8 / -	26.4 /	28.3 / -	
BUCKET ANGLE					
Dump Angle	109° (optional 118°)		118°	109° (optional 118°)	
Total Rotation Angle	131° (optional 142°)		142°	131° (optional 142°)	
ENGINE					
Type	4 cylinder, EURO Stage V, Common Rail Diesel, Turbo Intercooler				
Displacement (cm³)	4,485				
Rated Engine Power ISO TR14396 - ECE R120 (kW/CV)	89 / 121 @ 2,200 rpm	96 / 129 @ 2,200 rpm	89 / 121 @ 2,200 rpm	96 / 129 @ 2,200 rpm	96 / 129 @ 2,200 rpm
Max. Engine Power	98 / 133 @ 1,800 rpm	107 / 146 @ 1,800 rpm	98 / 133 @ 1,800 rpm	107 / 146 @ 1,800 rpm	107 / 146 @ 1,800 rpm
Max. torque (Nm @ engine rpm)	549 @ 1,500	591 @ 1,500	549 @ 1,500	549 @ 1,500	591 @ 1,500
Fuel tank/Urea capacity (Litres)	140 / 27				
TRANSMISSION					
6 x 3 Powershift (manual and auto shifting)	●				
Max. Travel Speed (kph)	30 or 40	35	40	30 or 40	40
AXLES					
Limited Slip differential Front and rear	4WD				
STEERING					
Steering Mode	2WS / 4WS / CRAB				
WEIGHTS AND DIMENSIONS					
A. Length fork heel to counter weight (mm)	5,005	5,472	5,005	5,239	5,239
B. Wheel Track (mm)	3,000	3,000	3,000	3,000	3,000
C. Ground Clearance (mm)	415	415	415	415	415
D. Max. Width (mm)	2,340	2,340	2,340	2,340	2,340
E. Wheel Base (mm)	1,873	1,873	1,873	1,873	1,873
F. Cab Height (mm)	2,447	2,447	2,447	2,447	2,447
Total weight with forks and operator (kg)	7,935	8,580	7,935	8,000	8,000
WHEELS AND TYRES					
Standard	460 / 70 R24				
Optional	500 / 70 R24				

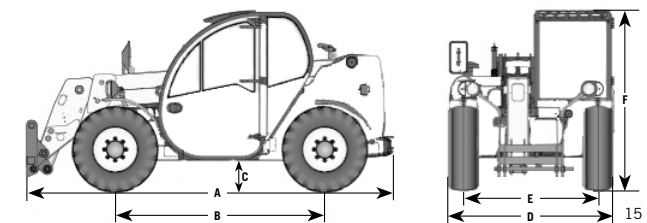

* To comply with legislation and specification in your country ¹⁾ with standard tyres ²⁾ ECE R120 correspond to ISO 14396 and 97/68/EC or 2000/25/EC
 ● Standard ○ Optional - not available



   
caseih.com

 Free phone: 00 800 22 73 44 00

Safety never hurts! Always read the Operator's Manual before working with any equipment. Inspect equipment before using it, and be sure it is operating properly. Follow the product safety signs, and use any safety features provided. This literature has been published for worldwide circulation. The standard and optional equipment and the availability of individual models may vary from one country to the next. Case IH reserves the right to undertake modifications without prior notice to the design and technical equipment at all times without this resulting in any obligation whatsoever to make such modifications to units already sold. Whilst every effort is made to ensure that the specifications, descriptions and illustrations in this brochure are correct at the time of going to press, these are also subject to change without prior notice. Illustrations may show optional equipment or may not show all standard equipment. Case IH recommends **AKCELA** lubricants.

TP01 / SM / 11.23 / Printed in Austria - Cod.No. 23C4001COMINB

CASE IH